

Accelerating and Breakdown Torque

The magnetic attraction of the rotating magnetic field will cause the rotor to accelerate. As the motor picks up speed torque decreases slightly until it reaches point B on the graph. As speed continues to increase from point B to point C torque increases until it reaches its maximum at approximately 200%. This torque is referred to as accelerating or pull up torque. Point C is the maximum torque a motor can produce. At this point a 30 HP motor will develop approximately 178.4 Lb-Ft of torque. If the motor were overloaded beyond the motor's torque capability, it would stall or abruptly slow down at this point. This is referred to as breakdown or pullout torque.

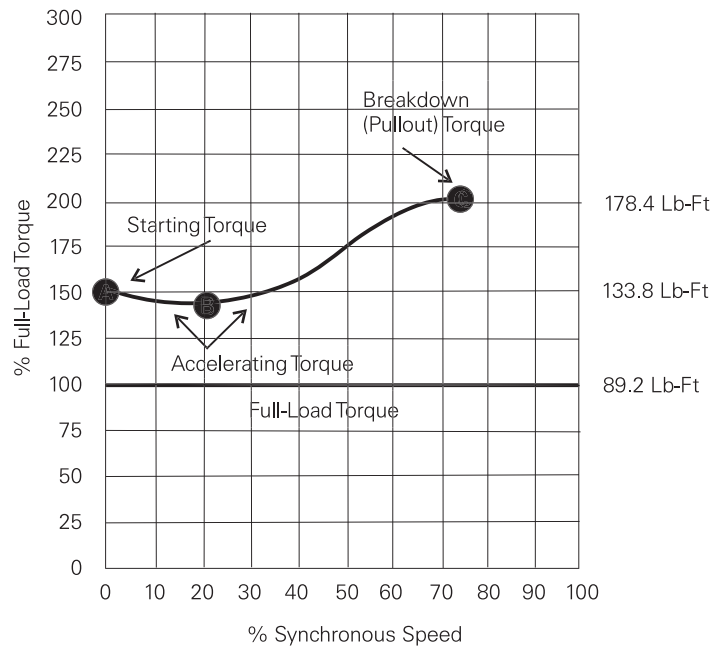

Full-Load Torque

Torque decreases rapidly as speed increases beyond breakdown torque (point C), until it reaches full-load torque at a speed slightly less than 100% synchronous speed. Full-load torque is the torque developed when the motor is operating with rated voltage, frequency and load. The speed at which full-load torque is produced is the slip speed or rated speed of the motor. Recall that slip is required to produce torque. If the synchronous speed of the motor is 1800 RPM and the amount of slip is 1.9%, the full-load rated speed of the motor is 1765 RPM. The full-load torque of the 1765 RPM 30 HP motor is 89.2 Lb-Ft. NEMA design B motors are general purpose single speed motors suited for applications that require normal starting and running torque such as conveyors, fans, centrifugal pumps, and machine tools.

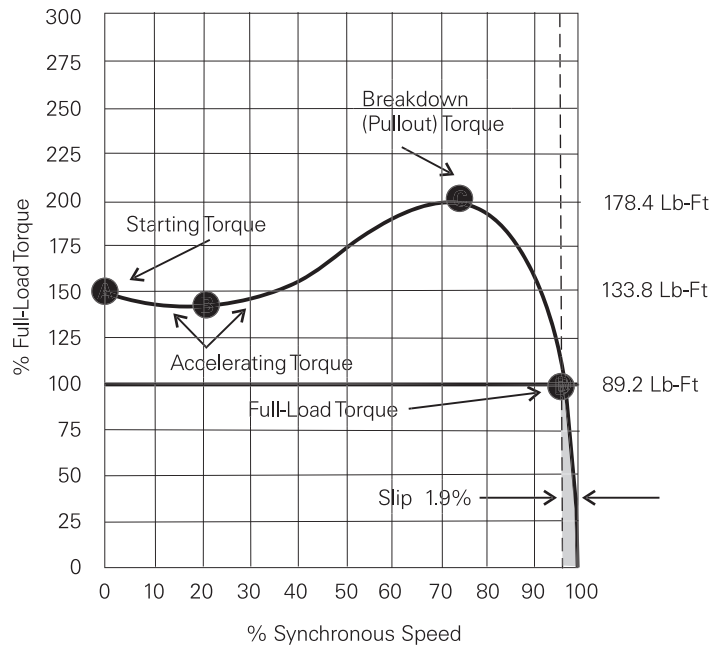

Starting Current and Full-Load Current

Starting current is also referred to as locked rotor current, and is measured from the supply line at rated voltage and frequency with the rotor at rest. Full-load current is the current measured from the supply line at rated voltage, frequency and load with the rotor up to speed. Starting current is typically 600-650% of full-load current on a NEMA B motor. Starting current decreases to rated full-load current as the rotor comes up to speed.

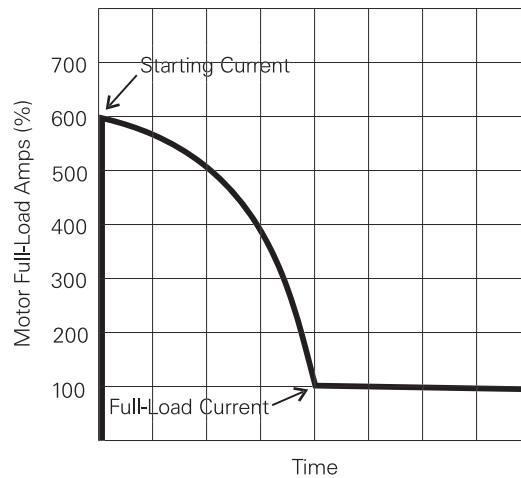

NEMA A Motor

NEMA sets limits of starting (locked rotor) current for NEMA design B motors. When special load torque or load inertia requirements result in special electrical designs that will yield higher locked rotor current (LRA), NEMA design A may result. This designation also cautions the selection of motor control components to avoid tripping protective devices during longer acceleration times or higher than normal starting current.

NEMA C Motor

Starting torque of a NEMA design C motor is approximately 225%. A NEMA C, 1765 RPM, 30 HP motor will develop approximately 202.5 Lb-Ft of starting torque. Hard to start applications such as plunger pumps, heavily loaded conveyors, and compressors require this higher starting torque. Slip and full-load torque are about the same as a NEMA B motor. NEMA C applies to single speed motors from approximately 5 HP to 200 HP.

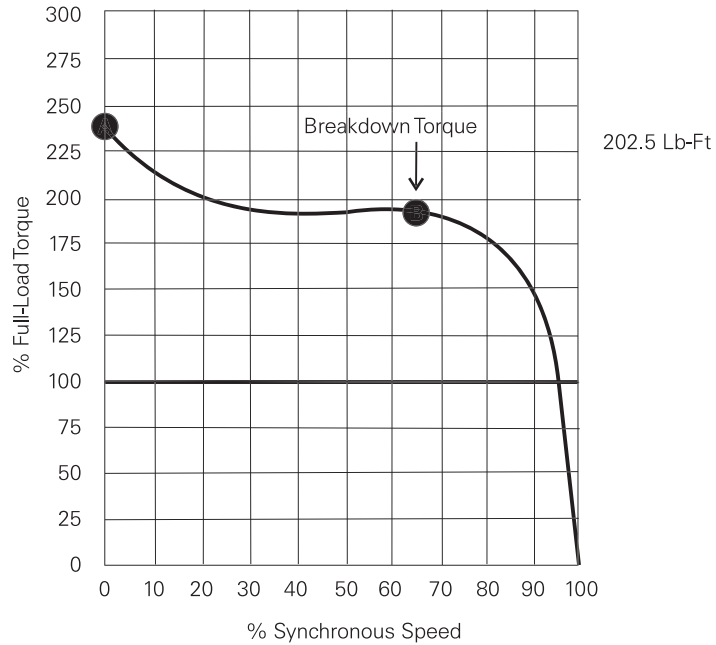

NEMA D Motor

The starting torque of a NEMA design D motor is approximately 280% of the motor's full-load torque. A NEMA D, with a full-load rated speed of 1765 RPM, 30 HP motor will develop approximately 252 Lb-Ft of starting torque. Very hard to start applications, such as punch presses, cranes, hoists, and oil well pumps require this high starting torque. NEMA D motors have no true breakdown torque. After initial starting torque is reached torque decreases until full-load torque is reached. NEMA D motors typically are designed with 5 to 8% slip or 8 to 13% slip.

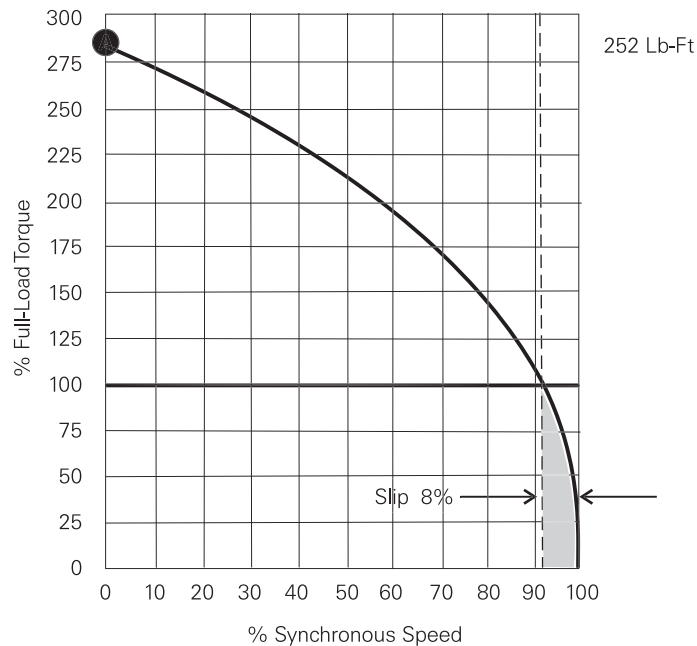

Multispeed and ASD (Adjustable Speed Drive)

These specialized motor designs are uniquely designed or selected to specific load requirements. NEMA design classifications are not applicable to these specialized motors.

Soft Starts

Various special configurations of motor controls are selected when starting/accelerating torques must be more accurately controlled, or when starting current must be limited. In the cases of part winding start or wye-delta start, the motor windings must be designed with unique connections for the special controls. In cases such as reduced voltage autotransformer or electronic soft starts, relatively standard motors may be approved for these special applications.

Review 5

1. A 30 HP motor with a 1.15 service factor can be operated at _____ HP.
2. A motor with Class F insulation has a maximum _____ temperature rise.
3. The starting torque of a NEMA B motor is approximately _____ % of full-load torque.
4. _____ torque refers to point on a torque curve where a motor is overloaded beyond the motor's torque capability, causing the motor to stall or abruptly slow down.

Derating Factors

Several factors can effect the operation and performance of an AC motor. These need to be considered when applying a motor.

Voltage Variation

AC motors are designed to operate on standardized voltages and frequencies. The following table reflects NEMA standards.

Standardized V _r ranges/Frequencies	
60 Hz	50 Hz
115 VAC	380 VAC
220 VAC	400 VAC
230 VAC	415 VAC
460 VAC	220/380 VAC
575 VAC	

A small variation in supply voltage can have a dramatic affect on motor performance. In the following chart, for example, when voltage is 10% below the rated voltage of the motor, the motor has 20% less starting torque. This reduced voltage may prevent the motor from getting its load started or keeping it running at rated speed. A 10% increase in supply voltage, on the other hand, increases the starting torque by 20%. This increased torque may cause damage during startup. A conveyor, for example, may lurch forward at startup. A voltage variation will cause similar changes in the motor's starting amps, full-load amps, and temperature rise.

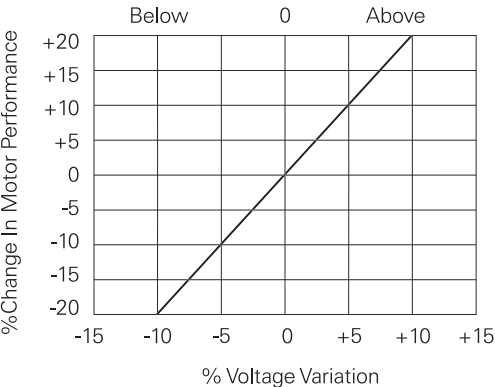

Frequency

A variation in the frequency at which the motor operates causes changes primarily in speed and torque characteristics. A 5% increase in frequency, for example, causes a 5% increase in full-load speed and a 10% decrease in torque.

Frequency Variation	% Change Full-Load Speed	% Change Starting Torque
+5%	+5%	-10%
-5%	-5%	+11%

Altitude

Standard motors are designed to operate below 3300 feet. Air is thinner and heat is not dissipated as quickly above 3300 feet. Most motors must be derated for altitude. The following chart gives typical horsepower derating factors, but the derating factor should be checked for each motor. A 50 HP motor operated at 6000 feet, for example, would be derated to 47 HP, providing the 40°C ambient rating is still required.

Altitude	Derating Factor
3300 - 5000	0.97
5001 - 6600	0.94
6601 - 8300	0.90
8301 - 9900	0.86
9901 - 11,500	0.82

$$50 \text{ HP} \times 0.94 = 47 \text{ HP}$$

Ambient Temperature

The ambient temperature may also have to be considered. The ambient temperature may be reduced from 40°C to 30°C at 6600 feet on many motors. A motor with a higher insulation class may not require derating in these conditions.

Ambient Temperature (°C)	Maximum Altitude (Feet)
40	3300
30	6600
20	9900

AC Motors and AC Drives

Many applications require the speed of an AC motor to vary. The easiest way to vary the speed of an AC induction motor is to use an AC drive to vary the applied frequency. Operating a motor at other than the rated frequency and voltage has an effect on motor current and torque.

Volts per Hertz

A ratio exists between voltage and frequency. This ratio is referred to as volts per hertz (V/Hz). A typical AC motor manufactured for use in the United States is rated for 460 VAC and 60 Hz. The ratio is 7.67 volts per hertz. Not every motor has a 7.67 V/Hz ratio. A 230 Volt, 60 Hz motor, for example, has a 3.8 V/Hz ratio.

$$\frac{460}{60} = 7.67 \text{ V/Hz} \quad \frac{230}{60} = 3.8 \text{ V/Hz}$$

Flux (Φ), magnetizing current (I_M), and torque are all dependent on this ratio. Increasing frequency (F) without increasing voltage (E), for example, will cause a corresponding increase in speed. Flux, however, will decrease causing motor torque to decrease. It can be seen that torque ($T = k\Phi I_w$) is directly affected by flux (Φ). Torque is also affected by the current resulting from the applied load, represented here by I_w . Magnetizing current (I_M) will also decrease. A decrease in magnetizing current will cause a corresponding decrease in stator or line (I_s) current. These decreases are all related and greatly affect the motor's ability to handle a given load.

$$\Phi \approx \frac{E}{F}$$

$$T = k\Phi I_w$$

$$I_M = \frac{E}{2\pi F L_M}$$

Constant Torque

AC motors running on an AC line operate with a constant flux (Φ) because voltage and frequency are constant. Motors operated with constant flux are said to have constant torque. Actual torque produced, however, is determined by the demand of the load.

$$T = k\Phi\omega$$

An AC drive is capable of operating a motor with constant flux (Φ) from approximately zero (0) to the motor's rated nameplate frequency (typically 60 Hz). This is the constant torque range. As long as a constant volts per hertz ratio is maintained the motor will have constant torque characteristics. AC drives change frequency to vary the speed of a motor and changes voltage proportionately to maintain constant flux. The following graphs illustrate the volts per hertz ratio of a 460 volt, 60 Hz motor and a 230 volt, 60 Hz motor. To operate the 460 volt motor at 50% speed with the correct ratio, the applied voltage and frequency would be 230 volts, 30 Hz. To operate the 230 volt motor at 50% speed with the correct ratio, the applied voltage and frequency would be 115 volts, 30 Hz. The voltage and frequency ratio can be maintained for any speed up to 60 Hz. This usually defines the upper limits of the constant torque range.

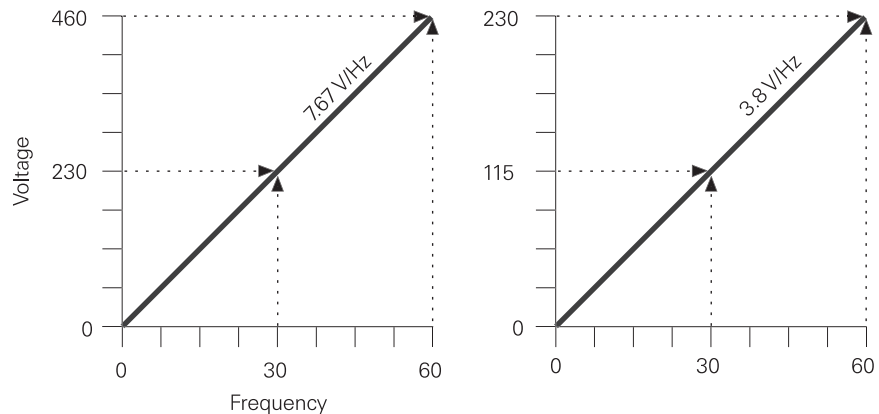

$$\frac{460}{60} = 7.67 \text{ V/Hz}$$

$$\frac{230}{30} = 7.67 \text{ V/Hz}$$

$$\frac{230}{60} = 3.8 \text{ V/Hz}$$

$$\frac{115}{30} = 3.8 \text{ V/Hz}$$

Constant Horsepower

Some applications require the motor to be operated above base speed. The nature of these applications requires less torque at higher speeds. Voltage, however, cannot be higher than the rated nameplate voltage. This can be illustrated using a 460 volt, 60 Hz motor. Voltage will remain at 460 volts for any speed above 60 Hz. A motor operated above its rated frequency is operating in a region known as a constant horsepower. Constant volts per hertz and torque is maintained up to 60 Hz. Above 60 Hz the volts per hertz ratio decreases, with a corresponding decrease in torque.

Frequency	V/Hz
30 Hz	7.67
60 Hz	7.67
70 Hz	6.6
90 Hz	5.1

Flux (Φ) and torque (T) decrease:

$$\Phi \approx \frac{E}{F} \quad T = k\Phi I_w$$

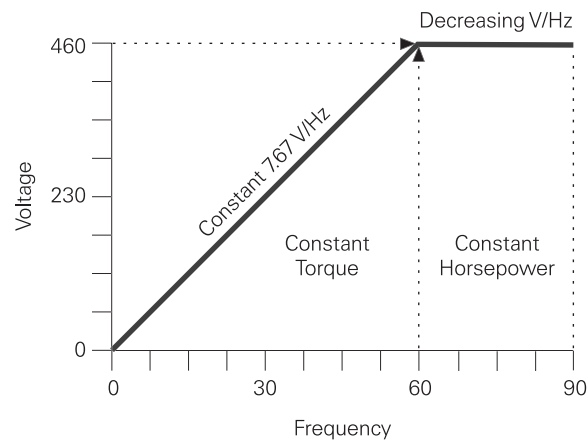

Horsepower remains constant as speed (N) increases and torque decreases in proportion. The following formula applies to speed in revolutions per minute (RPM).

$$\text{HP (remains constant)} = \frac{T \text{ (decreases)} \times N \text{ (increases)}}{5250}$$

Reduced Voltage and Frequency Starting

A NEMA B motor that is started by connecting it to the power supply at full voltage and full frequency will develop approximately 150% starting torque and 600% starting current. AC drives start at reduced voltage and frequency. The motor will start with approximately 150% torque and 150% current at reduced frequency and voltage. The torque/speed curve shifts to the right as frequency and voltage are increased. The dotted lines on the torque/speed curve illustrated below represent the portion of the curve not used by the drive. The drive starts and accelerates the motor smoothly as frequency and voltage are gradually increased to the desired speed. An AC drive, properly sized to a motor, is capable of delivering 150% torque at any speed up to speed corresponding to the incoming line voltage. The only limitations on starting torque are peak drive current and peak motor torque, whichever is less.

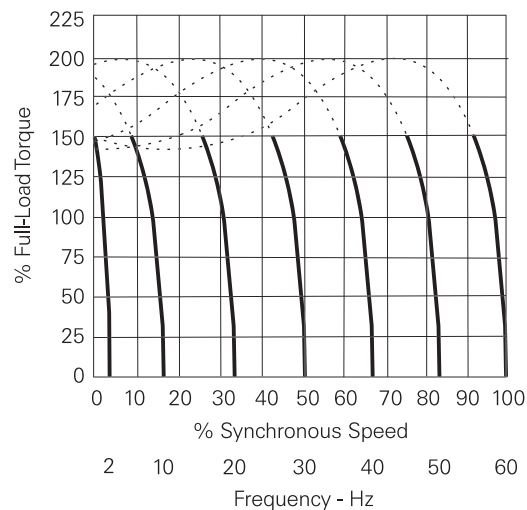

Some applications require higher than 150% starting torque. A conveyor, for example, may require 200% rated torque for starting. If a motor is capable of 200% torque at 200% current, and the drive is capable of 200% current, then 200% motor torque is possible. Typically drives are capable of producing 150% of drive nameplate rated current for one (1) minute. If the load requires more starting torque than a drive can deliver, a drive with a higher current rating would be required. It is appropriate to supply a drive with a higher continuous horsepower rating than the motor when high peak torque is required.

Selecting a Motor

AC drives often have more capability than the motor. Drives can run at higher frequencies than may be suitable for an application. Above 60 Hz the V/Hz ratio decreases and the motor cannot develop 100% torque. In addition, drives can run at low speeds, however, self-cooled motors may not develop enough air flow for cooling at reduced speeds and full load. Each motor must be evaluated according to its own capability before selecting it for use on an AC drive.

Harmonics, voltage spikes, and voltage rise times of AC drives are not identical. Some AC drives have more sophisticated filters and other components designed to minimize undesirable heating and insulation damage to the motor. This must be considered when selecting an AC drive/motor combination. Motor manufacturers will generally classify certain recommended motor selections based on experience, required speed range, type of load torque, and temperature limits.

Distance Between Drive and Motor

Distance from the drive to the motor must also be taken into consideration. All motor cables have line-to-line and line-to-ground capacitance. The longer the cable, the greater the capacitance. Some types of cables, such as shielded cable or cables in metal conduit, have greater capacitance. Spikes occur on the output of AC drives because of the charging current in the cable capacitance. Higher voltage (460 VAC) and higher capacitance (long cables) result in higher current spikes. Voltage spikes caused by long cable lengths can potentially shorten the life of the AC drive and motor. When considering an application where distance may be a problem, contact your local Siemens representative.

Service Factor on AC Drives

A high efficiency motor with a 1.15 service factor is recommended when used on an AC drive. Due to heat associated with harmonics of an AC drive, the 1.15 service factor is reduced to 1.0.

Matching AC Motors to the Load

One way to evaluate whether the torque capabilities of a motor meet the torque requirements of the load is to compare the motor's speed-torque curve with the speed-torque requirements of the load.

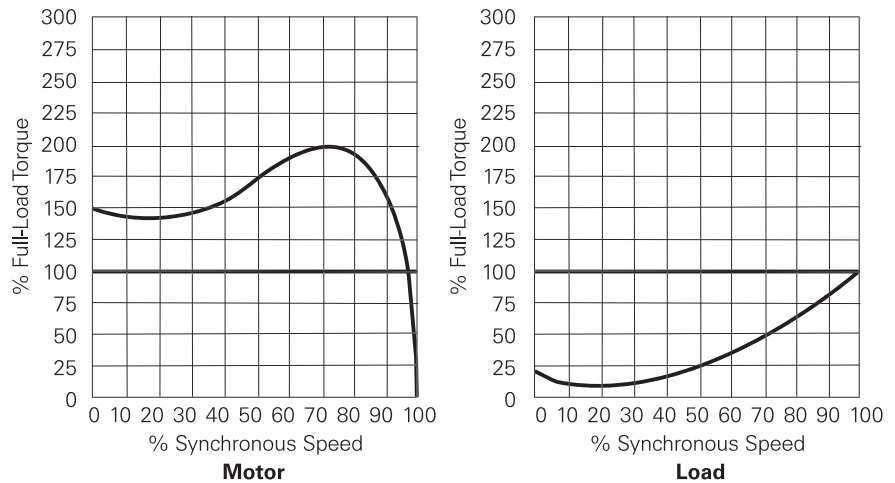

Load Characteristics Tables

To find the torque characteristics a table, similar to the partial one shown below, can be used. NEMA publication MG 1 is one source of typical torque characteristics.

Load Description	Load Torque as % Full-Load Drive Torque		
	Break-away	Accelerating	Peak Running
Actuators:			
Screw-down (rolling mills)	200	150	125
Positioning	150	110	100
Agitators			
Liquid	100	100	100
Slurry	150	100	100
Blowers, centrifugal:			
Valve closed	30	50	40
Valve open	40	110	100
Blowers, positive displacement, rotary, bypassed	40	40	100
Calenders, textile or paper	75	110	100

Calculating Load Torque

The most accurate way to obtain torque characteristics of a given load is from the equipment manufacturer. A simple experiment can be set up to show how torque of a given load can be calculated. In the following illustration a pulley is fastened to the shaft of a load. A cord is wrapped around the pulley with one end connected to a spring scale. The torque can be calculated by pulling on the scale until the shaft turns and noting the reading on the scale. The force required to turn the shaft, indicated by the scale, times the radius of the pulley equals the torque value. It must be remembered that the radius is measured from the center of the shaft. If the radius of the pulley and shaft were 1 foot, for example, and the force required to turn the shaft were 10 pounds, the torque requirement is 10 Lb-Ft. The amount of torque required to turn the connected load can vary at different speeds.

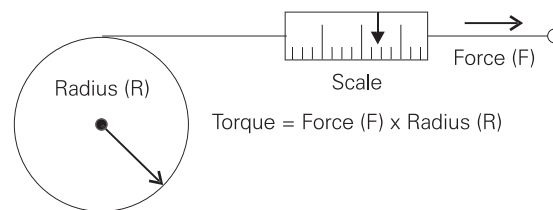

Centrifugal Pump

At any point during acceleration and while the motor is operating at full-load speed, the amount of torque produced by the motor must always exceed the torque required by the load. In the following example a centrifugal pump has a full-load torque of 600 Lb-Ft. This is equivalent to 200 HP. The centrifugal pump only requires approximately 20% of full-load torque to start. The torque dips slightly after it is started and then increases to full-load torque as the pump comes up to speed. This is typically defined as a variable torque load.

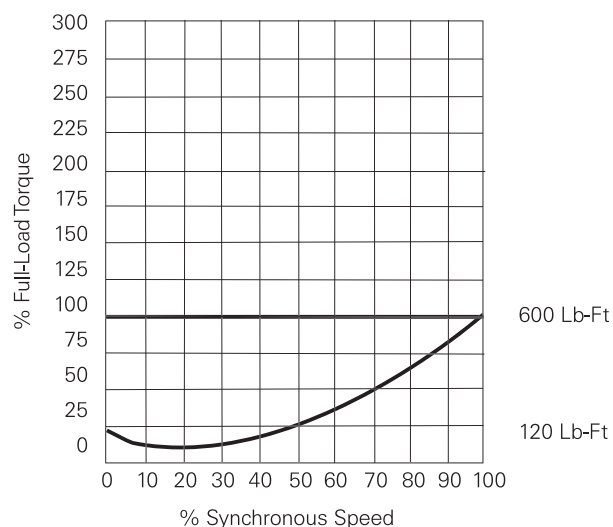

A motor has to be selected that can start and accelerate the centrifugal pump. By comparing a 200 HP NEMA B motor curve to the load curve, it can be seen that the motor will easily start and accelerate the load.

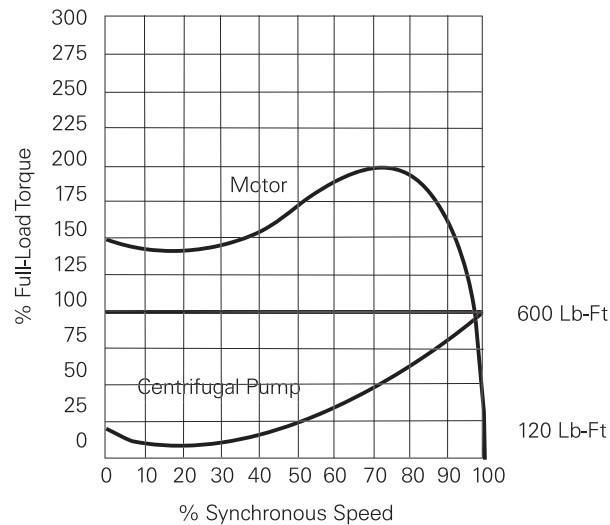

Screw Down Actuator

In the following example a screw down actuator is used. The starting torque of a screw down actuator is approximately 200% of full-load torque. Comparing the load's requirement (200%) with the NEMA design B motor of equivalent horsepower, it can be seen that the load's starting torque requirement is greater than the motor's capability (150%). The motor, therefore, will not start and accelerate the load.

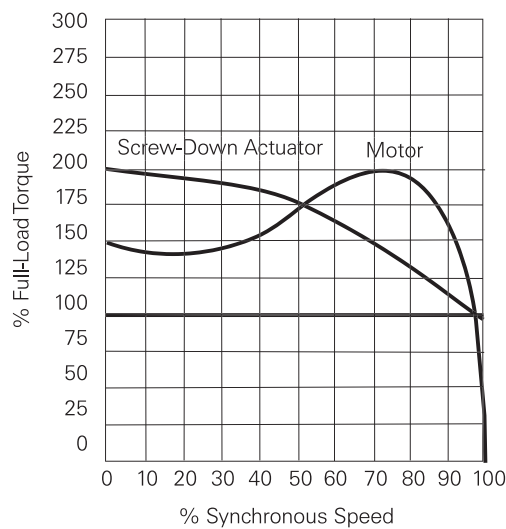

One solution would be to use a higher horsepower NEMA B motor. A less expensive solution might be to use a NEMA D motor of the same horsepower requirements as the load. A NEMA D motor would easily start and accelerate the load.

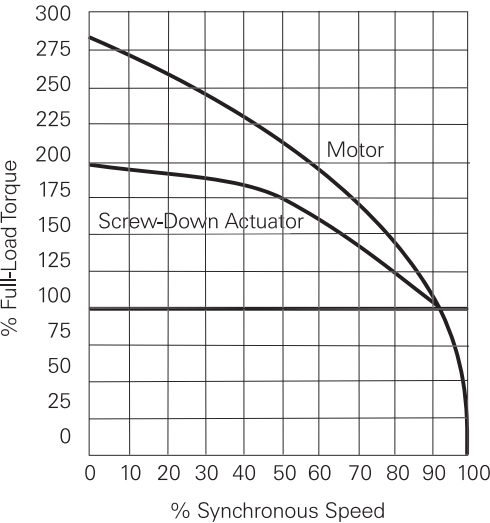

The motor selected to drive the load must have sufficient torque to start, accelerate, and run the load. If, at any point, the motor cannot produce the required torque the motor will stall or run in an overloaded condition. This will cause the motor to generate excess heat and typically exceed current limits causing protective devices to remove the motor from the power source. If the overload condition is not corrected, or the proper motor installed, the existing motor will eventually fail.

Review 6

1. A motor rated for 460 VAC operating on a supply of 437 VAC (-5%) will have a negative _____ % change in motor performance.
2. Using the altitude derating table the "Derating Factors" section, a 200 HP motor operated at 5500 feet would be derated to _____ HP.
3. The volts per hertz ratio of a 460 Volt 60 Hz motor is _____ V/Hz.
4. When applying an AC motor to an AC drive a motor with a _____ service factor is recommended.
5. If the radius of a pulley and shaft were 2 feet, and the force required to turn the shaft were 20 pounds, the amount of torque required to turn the load is _____ Lb-Ft.

Enclosures

Recall that the enclosure provides protection from contaminants in the environment in which the motor is operating. In addition, the type of enclosure affects the cooling of the motor. There are two categories of enclosures: open and totally enclosed.

Open Drip Proof (ODP)

Open enclosures permit cooling air to flow through the motor. The rotor has fan blades that assist in moving the air through the motor. One type of open enclosure is the drip proof enclosure. The vent openings on this type of enclosure prevent liquids and solids falling from above at angles up to 15° from vertical from entering the interior of the motor and damaging the operating components. When the motor is not in the horizontal position, such as mounted on a wall, a special cover may be necessary to protect it. This type of enclosure can be specified when the environment is free from contaminants.

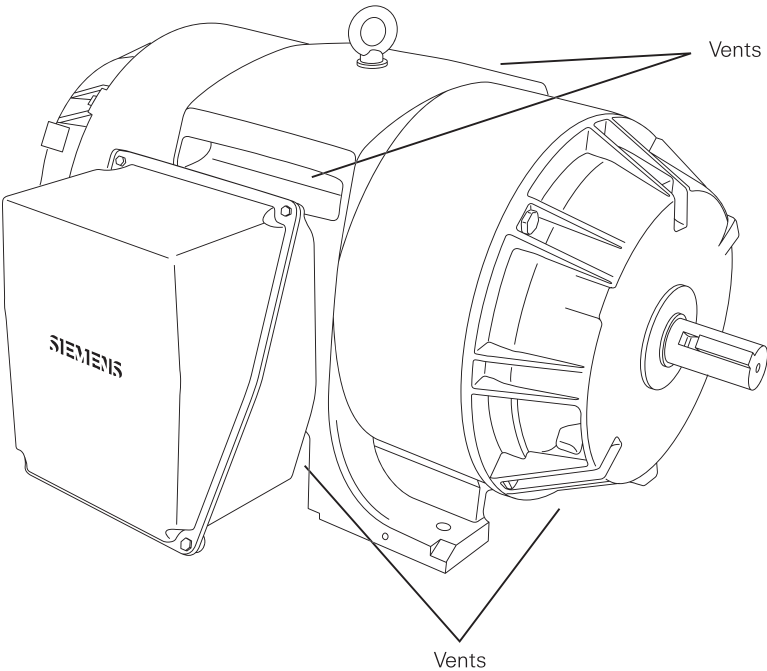

Totally Enclosed Non-Ventilated (TENV)

In some cases air surrounding the motor contains corrosive or harmful elements which can damage the internal parts of a motor. A totally enclosed motor enclosure restricts the free exchange of air between the inside of the motor and the outside. The enclosure is not airtight, however, and a seal at the point where the shaft passes through the housing keeps out water, dust, and other foreign matter that could enter the motor along the shaft. The absence of ventilating openings means all heat dissipates through the enclosure by means of conduction. Most TENV motors are fractional horsepower. TENV motors are used, however, for larger horsepower special applications. For larger horsepower applications the frame is heavily ribbed to help dissipate heat more quickly. TENV motors can be used indoors and outdoors.

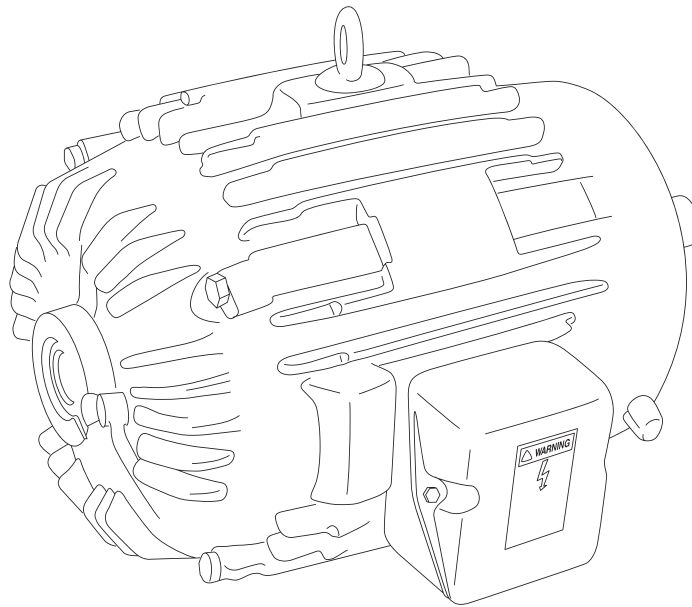

Totally Enclosed Fan Cooled (TEFC)

The totally enclosed fan-cooled motor is similar to the TENV except an external fan is mounted opposite the drive end of the motor. The fan provides additional cooling by blowing air over the exterior of the motor to dissipate heat more quickly. A shroud covers the fan to prevent anyone from touching it. With this arrangement no outside air enters the interior of the motor. TEFC motors can be used in dirty, moist, or mildly corrosive operating conditions. TEFC motors are more widely used for integral HP applications.

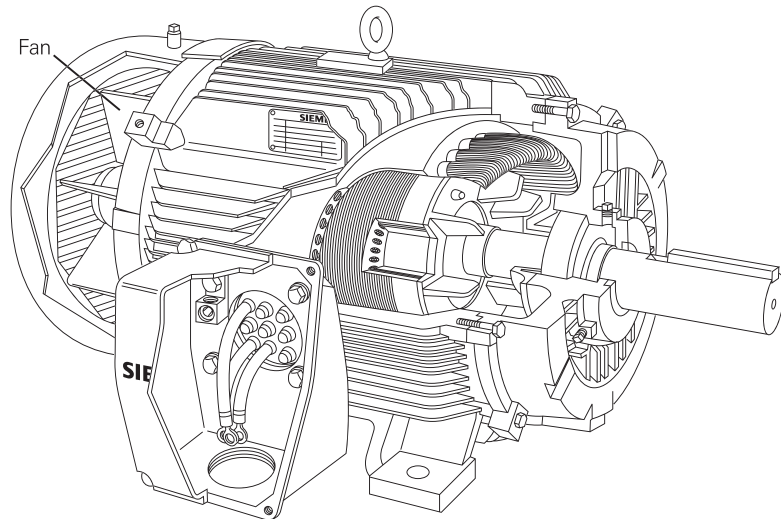

Explosion Proof (XP)

The explosion proof motor enclosure is similar in appearance to the TEFC, however, most XP enclosures are cast iron. The application of motors used in hazardous locations is subject to regulations and standards set by regulatory agencies such as the *National Electrical Code*® and Underwriters Laboratories for XP motors used in the United States.

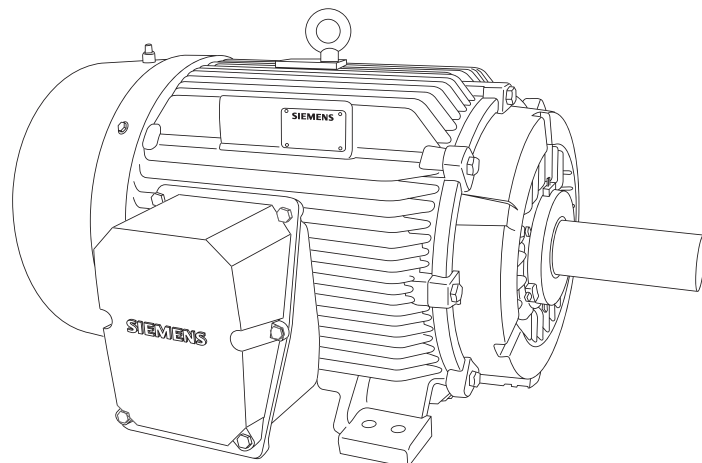

NEC® and *National Electrical Code*® are registered trademarks of the National Fire Protection Association.

Hazardous Environments

Although you should never specify or suggest the type of location, it is important to understand regulations that apply to hazardous locations. It is the user's responsibility to contact local regulatory agencies to define the location as Division I or II and to comply with all applicable codes. There are two divisions.

Division I

Hazardous materials are normally present in the atmosphere. A division I location requires an explosion proof motor.

Division II

Atmosphere may become hazardous as result of abnormal conditions. This may occur if, for example, a pipe breaks that is the conduit for a hazardous chemical.

Classes and Groups

Once the location is defined as hazardous the location is further defined by the class and group of hazard. Class I, Groups A through D are chemical gases or liquids such as gasoline, acetone, and hydrogen. Class II, Groups E, F, and G include flammable dust, such as coke or grain dust. Class III is not divided into groups. It includes all ignitable fibers and lints such as clothing fiber in textile mills.

Class I	Class II	Class III
Groups A-D Gasses and Liquids	Groups E-G Flammable Dust	Ignitable Fibers
Gasoline Acetone Hydrogen	Coke Dust Grain Dust Metalic Dust	Rayon Jute

In some cases it may be necessary for the user to define the lowest possible ignition temperature of the hazardous material to assure the motor complies with all applicable codes and requirements.

Mounting

NEMA Dimensions

NEMA has standardized frame size motor dimensions. Standardized dimensions include bolt hole size, mounting base dimensions, shaft height, shaft diameter, and shaft length. Existing motors can be replaced without reworking the mounting arrangement. New installations are easier to design because the dimensions are known. Letters are used to indicate where a dimension is taken. For example, the letter "C" indicates the overall length of the motor. The letter "E" represents the distance from the center of the shaft to the center of the mounting holes in the feet. The actual dimensions are found by referring to a table in the motor data sheet and referencing the letter to find the desired dimension.

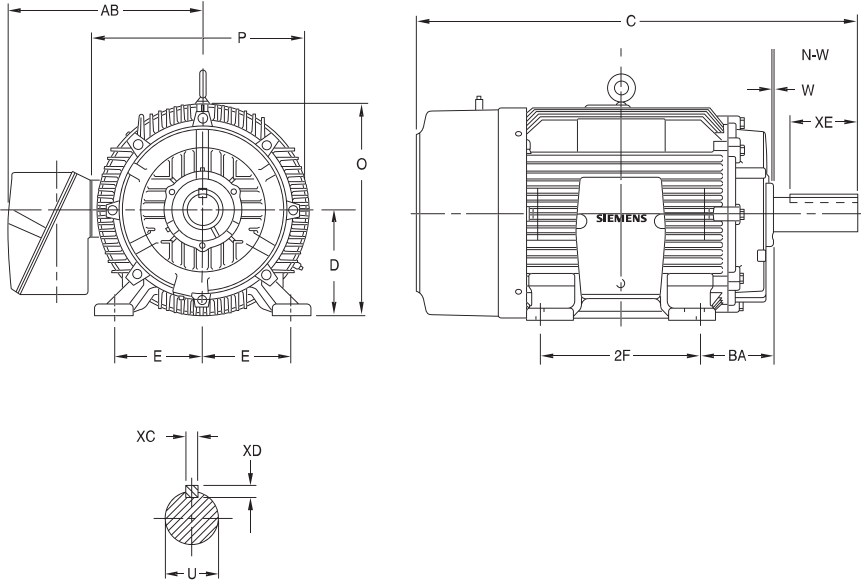

NEMA divides standard frame sizes into two categories: fractional and integral. Fractional frame sizes are designated 48 and 56 and include primarily horsepower ratings of less than one horsepower. Integral or medium horsepower motors are designated by frame sizes ranging from 143T to 445T. A "T" in the motor frame size designation of integral horsepower motors indicates the motor is built to current NEMA frame standards. Motors built prior to 1966 have a "U" in the motor frame size designation, indicated they are built to previous NEMA Standards.

143■ = Current NEMA Standards

326■ = Previous NEMA Standards

The frame size designation is a code to help identify key frame dimensions. The first two digits, for example, are used to determine the shaft height. The shaft height is the distance from the center of the shaft to the mounting surface. To calculate the shaft height divide the first two digits of the frame size by 4. In the following example a 143T frame size motor has a shaft height of 3½ inches ($14 \div 4$).

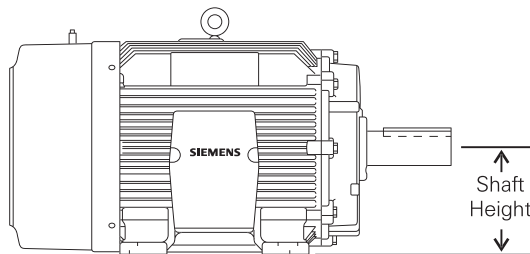

Frame ■3T
↓
 $14 \div 4 = 3\frac{1}{2}"$

The third digit in the integral “T” frame size number is the NEMA code for the distance between the center lines of the mounting bolt holes in the feet of the motor.

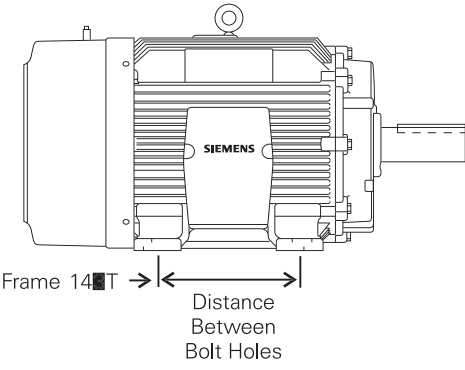

The dimension is determined by matching the third digit in the frame number with a table in NEMA publication MG-1. It can be seen that the distance between the center lines of the mounting bolt holes in the feet of a 143T frame is 4.00 inches.

Frame Number Series	D	Third/Fourth Digit In Frame Number				
		1	2	3	4	5
140				4.00	4.50	4.50
160	4.00	3.50	4.00	4.50	5.00	5.00
180	4.50	4.00	4.50	5.00	5.50	5.50
200	5.00	4.50	5.00	5.50	6.50	6.50
210	5.25	4.50	5.00	5.50	6.25	6.25
220	5.50	5.00	5.50	6.25	6.75	6.75
250	6.25	5.50	6.25	7.00	8.25	8.25
280	7.00	6.25	7.00	8.00	9.50	9.50
320	8.00	7.00	8.00	9.00	10.50	10.50

IEC Dimensions

IEC also has standardized dimensions which differ from NEMA. Many motors are manufactured using IEC dimensions. IEC dimensions are shown in the following drawing.

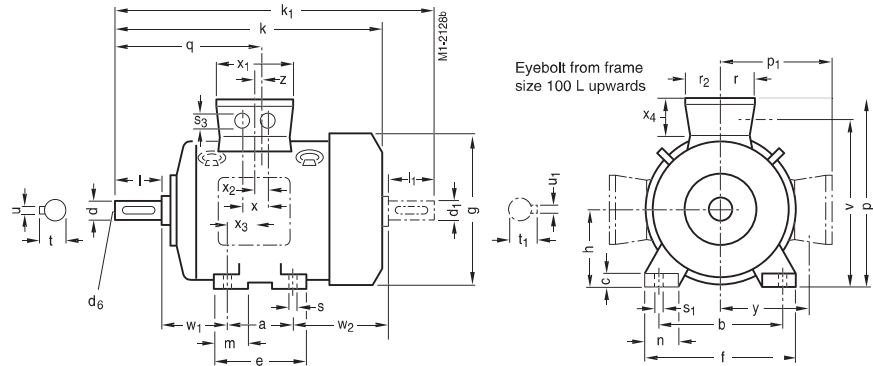

Mounting Positions

The typical floor mounting positions are illustrated in the following drawing, and are referred to as F-1 and F-2 mountings. The conduit box can be located on either side of the frame to match the mounting arrangement and position. The standard location of the conduit box is on the left-hand side of the motor when viewed from the shaft end. This is referred to as the F-1 mounting. The conduit opening can be placed on any of the four sides of the box by rotating the box in 90° steps.

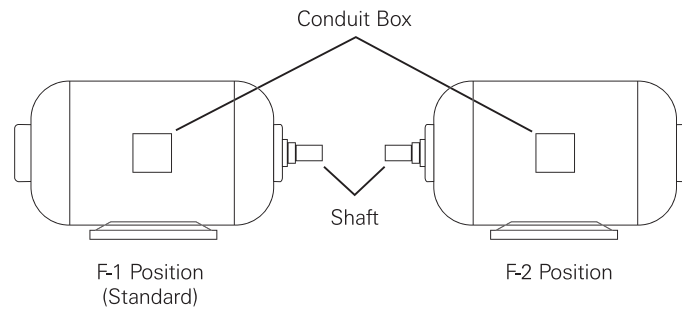

With modification the foot-mounted motor can be mounted on the wall and ceiling. Typical wall and ceiling mounts are shown in the following illustration. Wall mounting positions have the prefix "W" and ceiling mounted positions have the prefix "C."

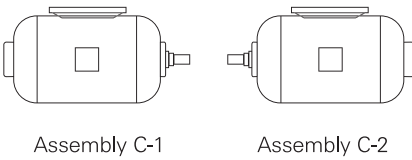
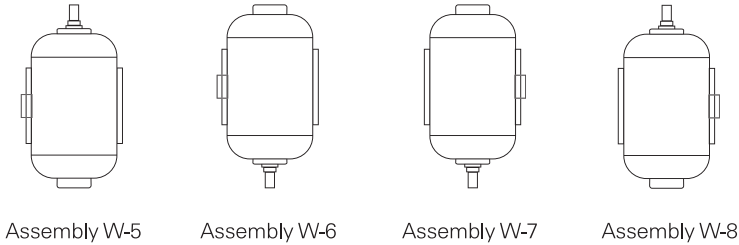
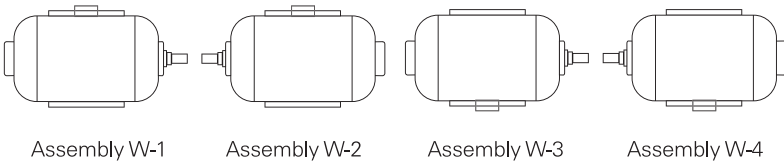

Mounting Faces

It is sometimes necessary to connect the motor directly to the equipment it drives. In the following example a motor is connected directly to a gear box.

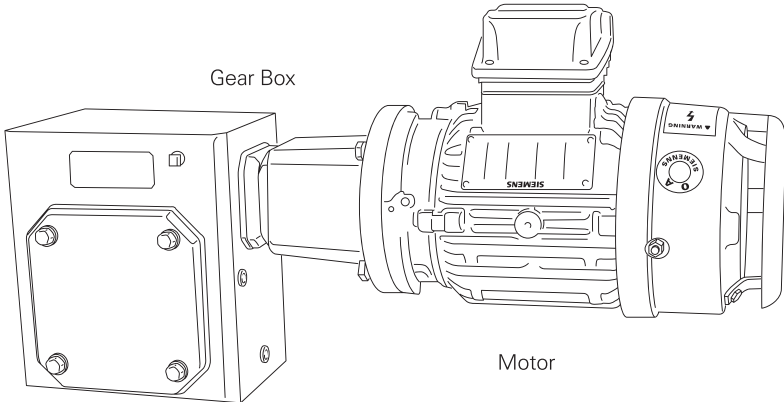

C-face

The face, or the end, of a C-face motor has threaded bolt holes. Bolts to mount the motor pass through mating holes in the equipment and into the face of the motor.

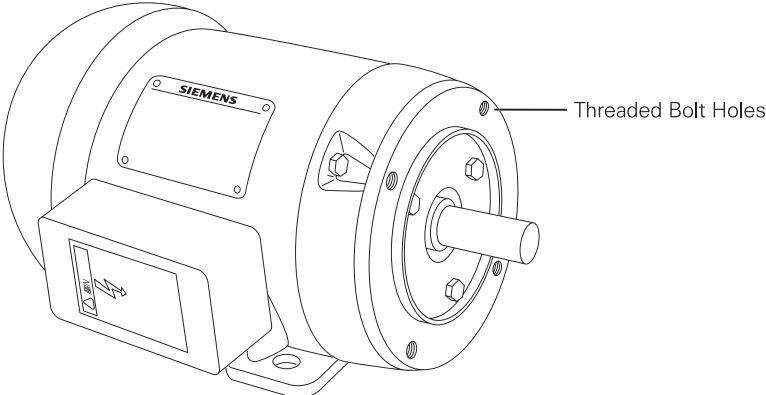

D-flange

The bolts go through the holes in the flange of a D-flange motor and into threaded mating holes of the equipment.

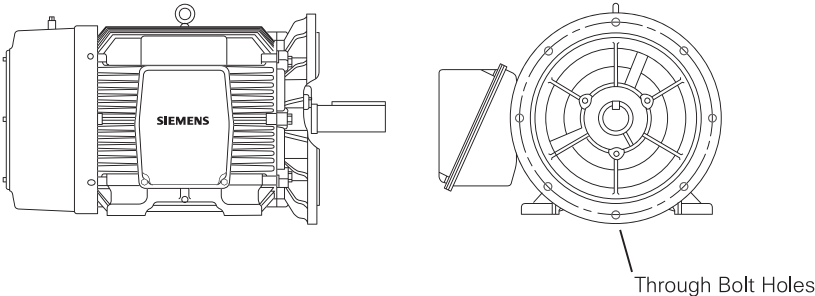

Review 7

1. A type of open enclosure that prevents liquids and solids falling from above at angles up to 15° from vertical from entering the interior of the motor is an _____ .
2. A type of enclosure that is closed and uses a fan mounted on the shaft to supply cooling is referred as _____ .
3. Gasoline is defined as a Class _____ hazard.
4. The NEMA dimension from the center of the shaft to the mounting surface is designated by the letter _____ .
5. The letter _____ in the motor frame size designation indicates a motor is built to current NEMA standards.
6. The shaft height can be determined by dividing the first two digits of an integral frame designation by _____ .
7. A motor intended to be mounted on the wall with the conduit box facing up and the shaft facing left is an Assembly _____ .
8. A _____ motor has threaded bolt holes to mount a motor to another piece of equipment.

Siemens Motors

Siemens manufactures a wide range of AC motors. The following information provides only an introduction to these motors. Contact your local Siemens representative for more information on any of the motors discussed or other Siemens AC motors.

Medallion™ Motors

Medallion motors represent the newer family of Siemens enclosed motors. Medallion EPAAct efficiency motors are high performance motors designed to meet the requirements of the U.S. Energy Policy Act of 1992 (EPAAct). EPAAct efficiency motors are available from 1 to 200 HP in both ODP and TEFC enclosures. Depending on the specific motor, EPAAct efficiency motors are wound for 900, 1200, 1800, or 3600 RPM when used on a 230 or 460 volt power supply. Premium efficiency Medallion motors are available from 1 to 400 horsepower. Depending on the specific motor, premium efficiency motors are wound for 900, 1200, 1800, or 3600 RPM when used on a 230/460 (460 only above 20 HP) volt power supply. EPAAct and premium efficiency motors are also available for use on other voltage sources such as 575 volt systems. Contact your Siemens representative for information and lead times.

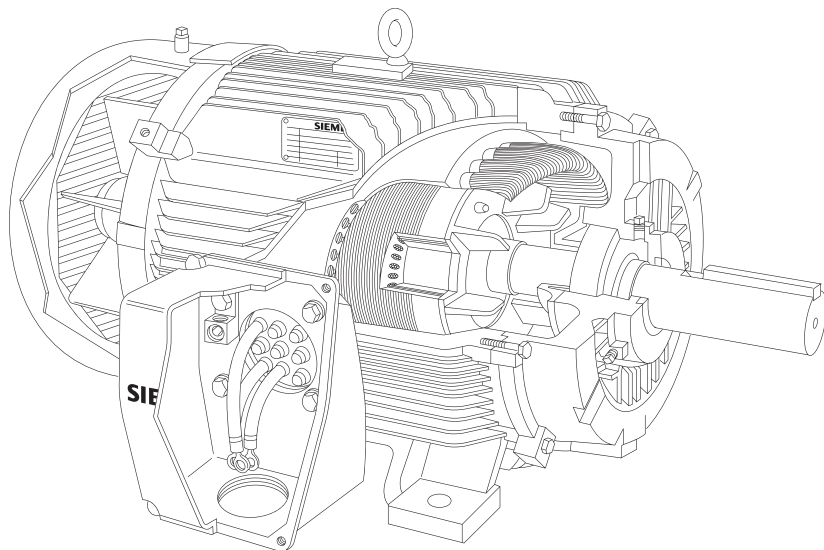

Medallion motors are available with longer shafts for belt driven applications and vertical mounting for applications such as pumps. Various protective devices, such as thermocouples and thermistors, can be installed as an option. These devices are wired into the motor controller and shut down the motor if temperature becomes excessive. Space heaters can also be used to keep the temperature of the motor above the dew point in areas that are damp or humid. Space heaters are turned off when the motor is running and on when the motor is stopped.

Medallion motors are also available in two-speed configurations. A two-speed motor often has two sets of windings, each wound with a different number of poles. The windings are brought out to an external controller. The motor can be run at either speed. Typical speed selections are 900 or 1200 RPM at low speed, and 1800 RPM at high speed.

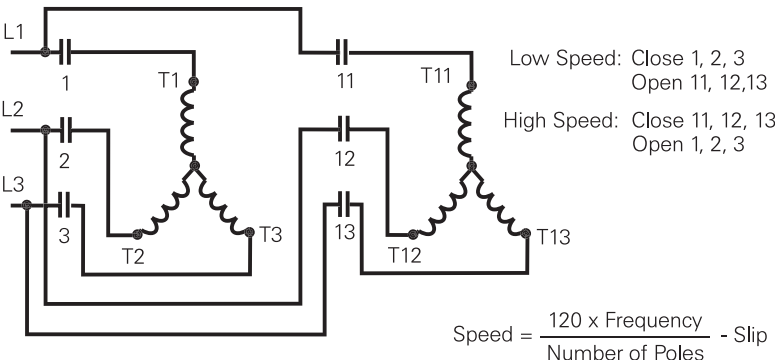

PE-21 Plus™ Motors

PE-21 Plus motors are premium efficiency motors available from 1 to 500 HP. Premium efficiency motors typically cost slightly more than standard efficiency motors, but payback is in energy savings.

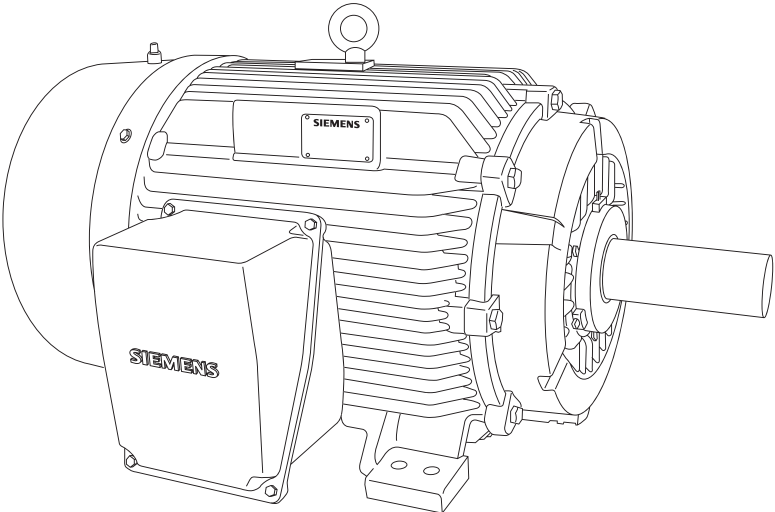

The following example is used to show energy savings available over the life of a premium efficiency motor. A 25 HP motor (Motor 1) with an efficiency of 86.5% costing \$590, and a PE-21 Plus with an efficiency of 93% costing \$768 are compared. Using a process life of 60,000 hours at \$.08 a kilowatt hour, the PE-21 Plus will save \$7,055 in total operating cost.

$$CL = P_i + \frac{.746 \times HP \times T_o \times R_u}{E}$$

CL Lifetime motor operating cost
 P_i Initial price of motor
 HP Motor horsepower
 T_o Lifetime hours of operation
 R_u Local utility rates - (\$/KWH)
 E Motor nameplate efficiency

Example:

25 HP, 1800 RPM, TEFC

Motor 1 F/L Eff. 86.5%
 Motor 1 P_i \$590

PE-21 Plus Eff. 93.0%
 PE-21 Plus P_i \$768

Motor 1

$$CL = 590 + \frac{.746 \times 25 \times 60,000 \times .08}{86.5}$$

CL = \$104,081

PE-21 Plus Motor

$$CL = 768 + \frac{.746 \times 25 \times 60,000 \times .08}{93.0}$$

CL = \$97,026

Savings = \$7,055

Vertical Pump Motors

Vertical hollow shaft pump motors are designed for vertical pump applications. The motors are squirrel cage induction type with NEMA design B torque and current characteristics. Motors are rated from 25 to 250 HP and 1800 RPM. Vertical pump motors are designed for 460 volt, 3-phase, 60 Hz systems. Thermostats and space heaters are optional.

These motors have NEMA standard P flange mounting shaft with a hollow shaft which accommodates the driven shaft to extend through the rotor. The coupling for connecting the motor shaft to the driven shaft is located in the top of the motor.

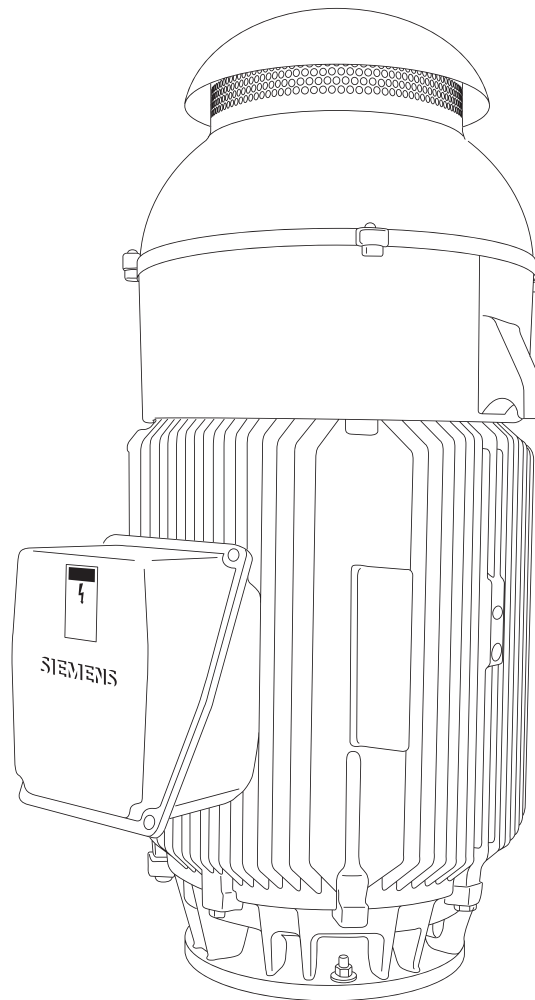

In addition to hollow shaft, more conventional solid shaft motors are supplied where the motor shaft is coupled to the driven shaft below the P flange face. Vertical solid shaft motors designed for in-line pump applications are available from 3 - 100 HP at 3600 RPM, and 3 - 250 HP at 1200 and 1800 RPM.

IEC Motors

IEC motors are manufactured to meet specifications of the International Electrotechnical Commission, IEC 34. Standard voltages at 50 Hz are 220, 400, 500, or 660 volts. Standard voltage at 60 Hz is 460 volts. Siemens IEC motors are available with 2, 4, 6, and 8 poles. IEC motors are also available for multispeed applications. Siemens IEC motors are available from 0.12 KW (0.16 HP) to 630 KW (840 HP).

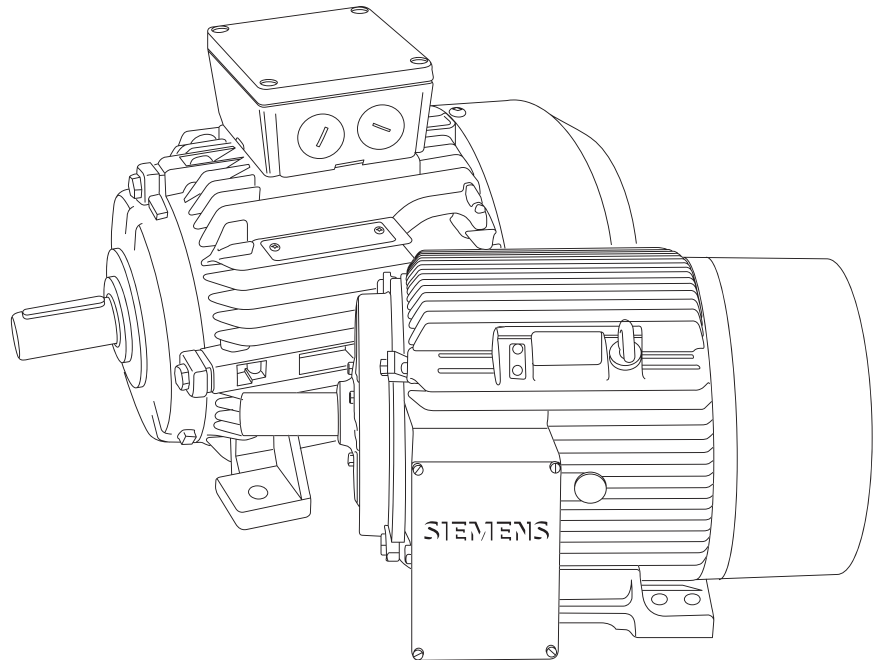

While mounting flange dimensions, shaft height, shaft extensions, and other performance standards clearly differ with comparable NEMA motors, a closer comparison will show remarkably similar characteristics. Perhaps the greatest obstacle to working with IEC motors is familiarity with unique terminology and the ability to correlate with more familiar NEMA standards.

Above NEMA Motors

Motors that are larger than the NEMA frame sizes are referred to as above NEMA motors. These motors typically range in size from 200 to 10,000 HP. Some above NEMA motors manufactured by Siemens may also be considered Medallion™ motors. There are no standardized frame sizes or dimensions because above NEMA motors are typically constructed to meet the specific requirements of an application. Siemens offers large motors in nine basic frame size series: 30, 500, 580, 680, 708, 788, 800, 880, and 1120 frames. For each frame size Siemens has standard frame dimensions similar to NEMA dimensions. For specific application information contact your local Siemens representative.

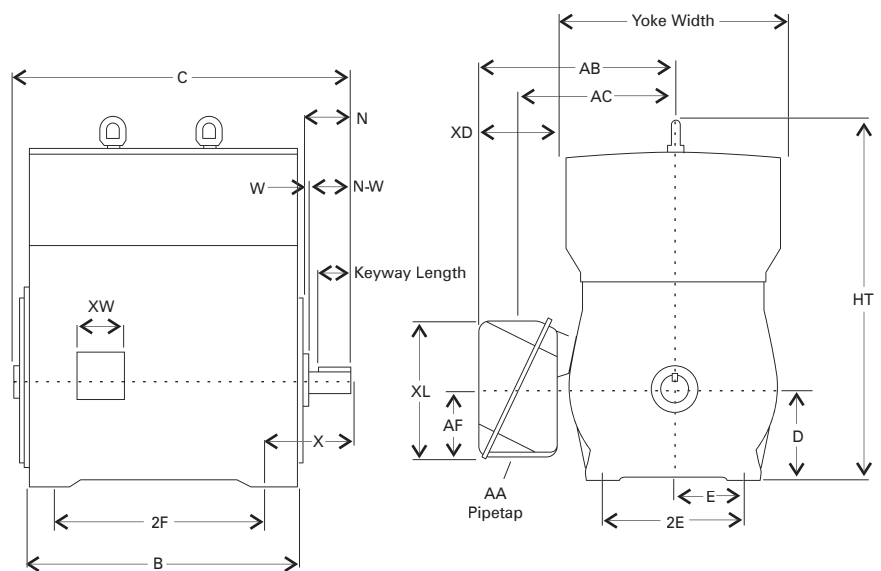

The customer typically supplies specifications for starting torque, breakdown torque, and full-load torque based on speed-torque curves obtained from the driven equipment manufacturer. There are, however, some minimum torques that all large AC motors must be able to develop. These are specified by NEMA.

- Locked Rotor Torque $\geq 60\%$ of Full-Load Torque
- Pull-Up Torque $\geq 60\%$ of Full-Load Torque
- Maximum Torque $\geq 175\%$ of Full-Load Torque

Above NEMA motors require the same adjustment for altitude and ambient temperature as integral frame size motors. When the motor is operated above 3300 feet a higher class insulation should be used or the motor should be derated. Above NEMA motors with class B insulation can easily be modified for operation in an ambient temperature between 40° C and 50° C. Above 50° C requires special modification at the factory.

Enclosures

Environmental factors also affect large AC motors. Enclosures used on above NEMA motors look differently than those on integral frame size motors.

Open Drip Proof (ODP) (Type CG)

Open drip proof enclosures provides the same amount of protection as the integral frame size open motor. This provides the least amount of protection for the motor's electrical components. ODP enclosures are used on indoor applications in environments free of contaminants. This enclosure is available up to 10,000 HP.

Weather Protected I (WPI) (Type CG)

The weather protected I enclosure is an open enclosure that has ventilating passages designed to minimize the entrance of airborne particles that could come into contact with the electrical and rotating parts of the motor. All air inlets and exhaust vents are covered with screens. It is used on indoor applications either free of or containing minimal contaminants. This enclosure is available to 10,000 horsepower.

ODP and WPI Enclosures

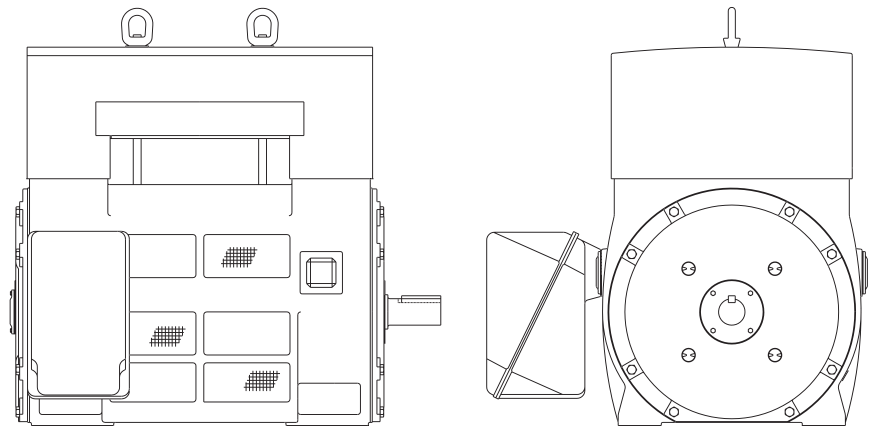

580, 680, and 800 Frames

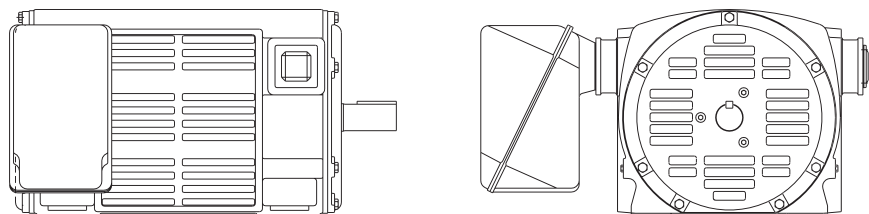

500 Frame

**Weather Protected II (WP/II)
(Type CG/II)**

Weather protected II enclosures are open enclosures with vents constructed so that high velocity air and airborne particles blown into the motor can be discharged without entering the internal ventilating passages leading to the electrical parts of the motor. The intake and discharge vents must have at least three 90° turns and the air velocity must be less than 600 feet per minute. It is used on outdoor applications when the motor is not protected by other structures. This enclosure is available up to 10,000 horsepower.

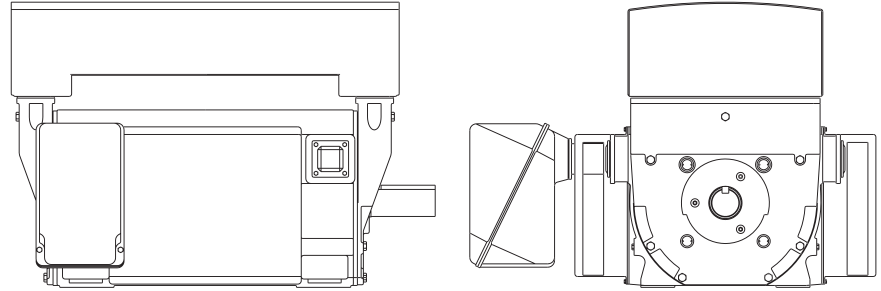

Totally Enclosed Fan Cooled (Type CZ and CGZ)

The totally enclosed fan cooled motor functions the same as the TEFC enclosure used on integral frame size motors. It is designed for indoor and outdoor applications where internal parts must be protected from adverse ambient conditions. Type CZ and CGZ utilize cooling fins both all around the yoke and the bearing housings. This enclosure is available up to 600 HP on 500 frames, 900 horsepower on 580 frames, and 2250 horsepower on 708-880 frames.

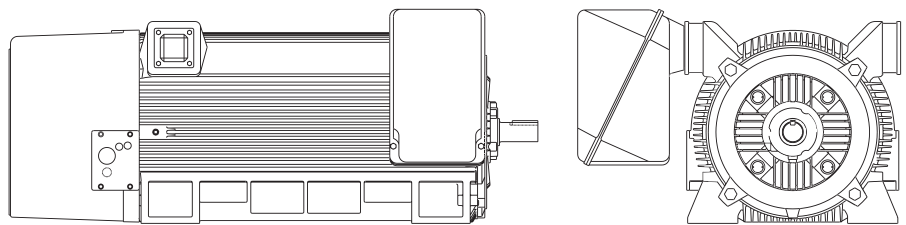

Totally Enclosed Air to Air Cooled (Type TEAAC) (Type CAZ)

Type TEAAC totally enclosed motor utilize air to tube type heat exchangers for cooling. This enclosure is available up to 7,000 HP.

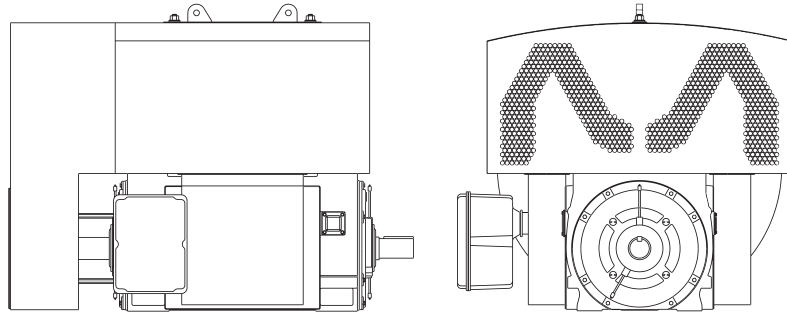

Totally Enclosed Water Cooled (TEWAC) (Type CGG)

There comes a point when the motor frame cannot adequately dissipate heat, even with the help of a fan. This enclosure is designed to cool the motor by means of a water-to-air heat exchanger. This type of enclosure requires a steady supply of water. This enclosure is available up to 10,000 HP.

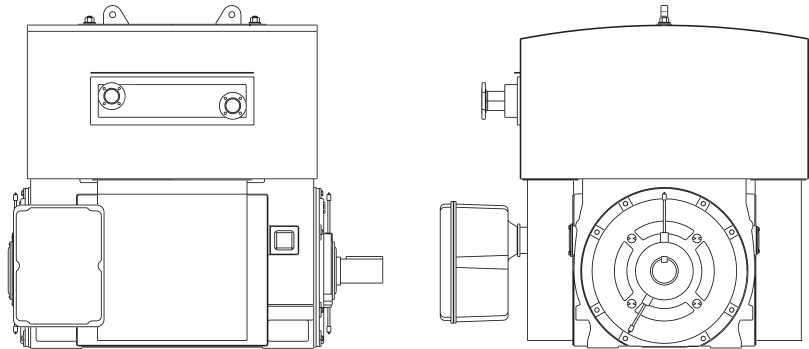

Totally Enclosed Fan Cooled Explosion Proof (TEFC-XP) (Type CGZZ and AZZ)

Large AC motors are also used in hazardous environments. This enclosure meets or exceeds all applicable UL requirements for hazardous (Division 1) environmental operation. This enclosure is available up to 1750 HP.

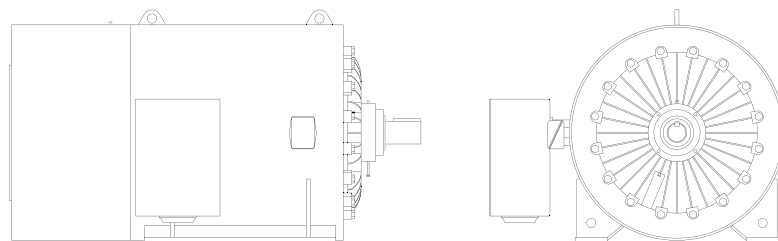

Review 8

1. TEFC EPCAct efficiency Medallion motors are available from 1 to _____ horsepower.
2. PE-21 Plus motors are available from 1 to _____ horsepower.
3. An advantage of a premium efficiency motor over a standard efficiency motor is a savings in _____ over the operating life of the motor.
4. Vertical pump motors have NEMA design _____ torque and current characteristics.
5. IEC motors are built to IEC _____ standards.
6. Above NEMA motors are available from _____ to _____ HP.
7. Locked rotor torque of an above NEMA motor is \geq _____ % of full-load torque.

Review Answers

- Review 1** 1) force; 2) 15; 3) torque; 4) 80; 5) inertia; 6) Speed; 7) revolutions per minute; 8) Acceleration
- Review 2** 1) A. enclosure, B. stator, C. rotor; 2) stator and rotor; 3) stator; 4) rotor; 5) squirrel cage
- Review 3** 1) north, south; 2) A. attract, B. repel, C. repel D. attract; 3) magnetic field; 4) D
- Review 4** 1) 2, north; 2) synchronous; 3) 1800; 4) slip; 5) 4.2
- Review 5** 1) 34.5; 2) 105°C; 3) 150; 4) Breakdown
- Review 6** 1) 10; 2) 188; 3) 7.67; 4) 1.15; 5) 40
- Review 7** 1) open drip proof; 2) totally enclosed fan cooled; 3) I; 4) D; 5) T; 6) 4; 7) W-2; 8) C-face
- Review 8** 1) 200; 2) 500; 3) energy; 4) B; 5) 34; 6) 200 to 10,000; 7) 60

Final Exam

The final exam is intended to be a learning tool. The book may be used during the exam. A tear-out answer sheet is provided. After completing the test, mail the answer sheet in for grading. A grade of 70% or better is passing. Upon successful completion of the test a certificate will be issued.

1. _____ is a twisting or turning force that causes an object to rotate.
 - a. Torque
 - b. Friction
 - c. Inertia
 - d. Acceleration

2. If 50 pounds of force were applied to a lever 3 feet long, the torque would be _____ Lb-Ft.
 - a. 16.7
 - b. 53
 - c. 47
 - d. 150

3. The rate of doing work is called _____ .
 - a. inertia
 - b. speed
 - c. power
 - d. energy

4. A motor with a rating of 60 KW would have an equivalent rating of _____ HP.
 - a. 45
 - b. 80
 - c. 65
 - d. 120

5. Three basic parts of an AC motor are the _____ .
 - a. rotor, stator, and enclosure
 - b. shaft, housing, and connection box
 - c. cooling fan, rotor, and stator
 - d. end brackets, bearings and cooling fan

6. A four-pole motor operating at 50 Hz has a synchronous speed of _____ RPM.
 - a. 1500
 - b. 3000
 - c. 1800
 - d. 3600

7. A motor with a synchronous speed of 900 RPM and a rotor speed of 850 RPM has _____ % slip.
- a. 3
 - b. 9.4
 - c. 5.5
 - d. 20
8. _____ is an indication of how much electrical energy is converted into mechanical energy.
- a. Service factor
 - b. Efficiency
 - c. Temperature rise
 - d. RPM
9. _____ torque is also referred to as starting torque.
- a. Pull up
 - b. Accelerating
 - c. Breakdown
 - d. Locked rotor
10. A NEMA B motor that is started by connecting it to the power supply at rated voltage and frequency has a typical starting current of _____ %.
- a. 100
 - b. 150
 - c. 200
 - d. 600
11. The temperature rise of a motor with Class F insulation is _____ ° C with a 10° C hot spot.
- a. 60
 - b. 105
 - c. 80
 - d. 125
12. The volts per hertz ratio of a 460 VAC, 60 Hz motor is _____ V/Hz.
- a. 3.8
 - b. 7.67
 - c. 5.1
 - d. 9.2
13. A motor operated within a speed range that allows a constant volts per hertz ratio is said to be _____ .
- a. constant hp
 - b. variable torque
 - c. constant torque
 - d. variable flux
14. A +5% variation in frequency can have a _____ % change in starting torque.
- a. +5%
 - b. -5%
 - c. -10%
 - d. +10%

15. The following graph represents a NEMA _____ motor.

- a. A
- b. B
- c. C
- d. D

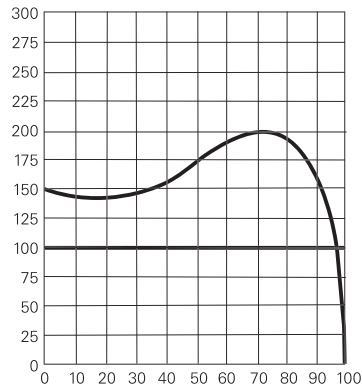

16. A _____ motor enclosure uses vent openings to prevent liquids and solids falling from above at angles from up to 15° from vertical from entering the interior of the motor.

- a. TENV
- b. XP
- c. TEFC
- d. ODP

17. Grain dust is in a hazardous location Class _____ .

- a. II
- b. III
- c. A
- d. C

18. The letter _____ in the motor frame size designation of an integral horsepower motor indicates the motor is built to current NEMA standards.

- a. C
- b. U
- c. T
- d. N

19. The shaft height of a 449 frame integral horsepower motor is _____ inches.

- a. 3½
- b. 9
- c. 4.4
- d. 11

20. PE-21 Plus™ motors are available from 1 to _____ HP.

- a. 500
- b. 1200
- c. 800
- d. 2500

quickSTEP Online Courses

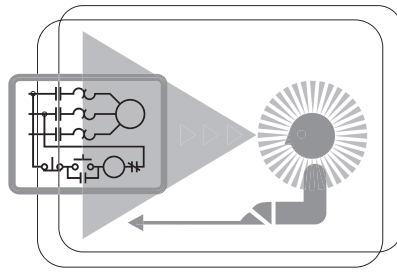

quickSTEP online courses are available at <http://www.sea.siemens.com/step>.

The quickSTEP training site is divided into three sections: Courses, Downloads, and a Glossary. Online courses include reviews, a final exam, the ability to print a certificate of completion, and the opportunity to register in the Sales & Distributor training database to maintain a record of your accomplishments.

From this site the complete text of all STEP courses can be downloaded in PDF format. These files contain the most recent changes and updates to the STEP courses.

A unique feature of the quickSTEP site is our pictorial glossary. The pictorial glossary can be accessed from anywhere within a quickSTEP course. This enables the student to look up an unfamiliar word without leaving the current work area.

